



Shown with optional assemblies.

EC042B Series

The EC042B Series Brushless DC Motor is an excellent choice for both power transmission and precision motion control applications. It is offered in 3 motor lengths with continuous torque from 0.064 - 0.17 Nm. The EC042B is a high torque density 4 pole model designed as an economical yet higher performance general purpose servo motor. It is a great choice if more torque is needed in a 42 mm motor.

EC Instrument Grade Motors For applications that require uniform motion control at all speeds. Capable of high acceleration.

Motor Characteristics

Motor Data	Units	Part No.		
		EC042B-1	EC042B-2	EC042B-3
Max DC Terminal Voltage	V_T	96		
Max Speed (Mechanical)	ω_{MAX}	9000		
Continuous Stall Torque ¹	T_{CS}	0.064	0.12	0.17
		9.0	17	24
Peak Torque (Maximum) ¹	T_{pk}	0.38	0.39	0.55
		54	55	79
Coulomb Friction Torque	T_f	0.0014	0.0028	0.0042
		0.20	0.40	0.60
Viscous Damping Factor	D	3.4E-06	4.7E-06	6.7E-06
		0.050	0.070	0.10
Thermal Time Constant	τ_{th}	5.1	11	16
Thermal Resistance	R_{th}	9.1	5.9	4.4
Max. Winding Temperature	θ_{MAX}	105	105	105
Rotor Inertia	J_r	1.4E-05	1.8E-05	2.1E-05
		0.0021	0.0025	0.0029
Motor Weight	W_m	340	540	730
		12	19	26

¹Recorded at maximum winding temperature at 25°C ambient and without heatsink.

Benefits

- Speeds up to 9,000 RPM possible
- DC bus voltage up to 96 VDC
- Large bearings for high side loads
- Metric mounting
- Eight standard windings per stack, special windings available

Optional Assemblies

- Encoders: E30C/D, H Type
- Gearboxes: PLG42S, PLG52
- Programmable Drives: PBL4850E, BGE3004A, BGE6015A

Dimensional Drawings: EC042B-1 • EC042B-2 • EC042B-3

Dimensions = metric [mm]

L = Lengths Available

EC042B-1 = 54.5 mm

EC042B-2 = 74.5 mm

EC042B-3 = 94.5 mm

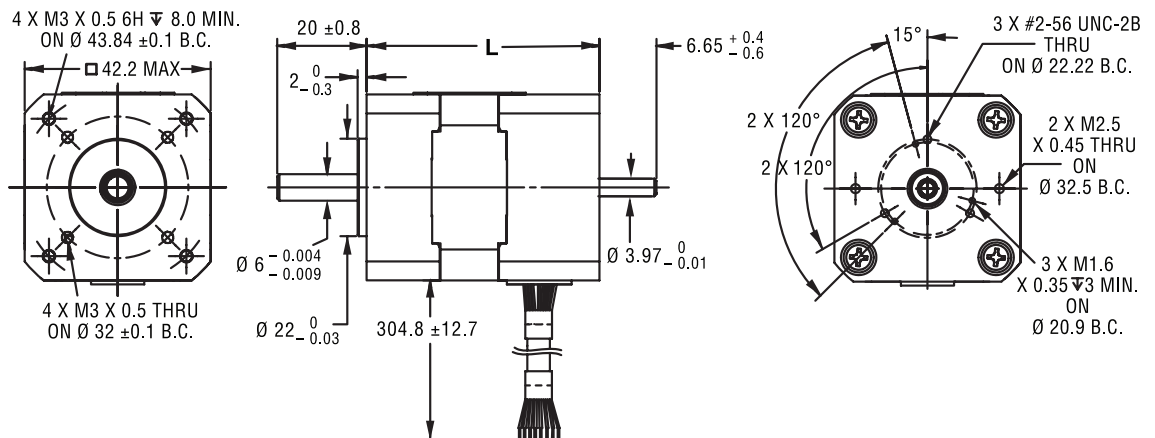

Motor Data		Units										
Rated Voltage V1	V_r	V	12.0	15.2	12.0	15.2	19.1	24.0	30.3	38.2	48.0	60.6
Rated Torque ¹ •	T_r	Nm	0.057	0.057	0.057	0.057	0.058	0.058	0.058	0.056	0.056	0.058
		oz-in	8.1	8.1	8.1	8.1	8.2	8.2	8.2	8.0	8.0	8.2
Rated Speed ¹	ω_r	rpm	5380	5310	5380	5310	5360	5400	5530	5160	5100	5460
Rated Current ¹	I_r	A	3.4	2.7	3.4	2.7	2.2	1.8	1.4	1.0	0.82	0.70
Rated Power ¹	P_r	W	32	32	32	32	33	33	34	31	30	33
No Load Speed	ω_{nl}	rpm	6280	6210	6280	6210	6250	6280	6400	6090	6030	6340
No Load Current	I_{nl}	A	0.21	0.16	0.21	0.16	0.13	0.11	0.082	0.061	0.048	0.041
Rated Voltage V2	V_r	V	7.58	9.55	7.58	9.55	12.0	15.2	19.1	24.0	30.3	38.2
Rated Torque ¹ •	T_r	Nm	0.062	0.063	0.062	0.063	0.064	0.063	0.064	0.061	0.061	0.063
		oz-in	8.8	8.9	8.8	8.9	9.0	9.0	9.1	8.7	8.7	8.9
Rated Speed ¹	ω_r	rpm	2900	2840	2900	2840	2880	2930	2990	2740	2710	2950
Rated Current ¹	I_r	A	3.7	2.9	3.7	2.9	2.4	1.9	1.5	1.1	0.88	0.75
Rated Power ¹	P_r	W	19	19	19	19	19	19	20	18	17	19
No Load Speed	ω_{nl}	rpm	3960	3900	3960	3900	3920	3970	4030	3820	3800	3990
No Load Current	I_{nl}	A	0.16	0.13	0.16	0.13	0.097	0.079	0.064	0.047	0.037	0.032
Motor Constant	K_M	Nm/ \sqrt{W}	0.027	0.027	0.027	0.027	0.028	0.027	0.028	0.027	0.026	0.027
		oz-in/ \sqrt{W}	3.8	3.8	3.8	3.8	3.9	3.9	3.9	3.8	3.7	3.9
Torque Constant	K_T	Nm/A	0.0181	0.0231	0.0181	0.0231	0.0289	0.0361	0.0448	0.0592	0.0751	0.0903
		oz-in/A	2.56	3.27	2.56	3.27	4.09	5.11	6.34	8.39	10.6	12.8
Voltage Constant	K_E	V/(rad/s)	0.0181	0.0231	0.0181	0.0231	0.0289	0.0361	0.0448	0.0592	0.0751	0.0903
		V/krpm	1.89	2.42	1.89	2.42	3.03	3.78	4.69	6.20	7.87	9.46
Terminal Resistance	R_{mt}	Ω	0.446	0.724	0.446	0.724	1.10	1.72	2.61	4.97	8.05	10.9
Inductance	L	mH	0.57	0.94	0.57	0.94	1.5	2.3	3.5	6.2	9.9	14
Peak Current	I_{pk}	A	23	9.0	23	9.0	7.5	6.0	4.8	3.6	2.7	2.4
Electrical Time Constant	τ_e	ms	1.3	1.3	1.3	1.3	1.3	1.3	1.4	1.2	1.2	1.3
Mechanical Time Constant	τ_m	ms	20	20	20	20	19	19	19	20	21	19

¹Recorded at maximum winding temperature at 25°C ambient and without heatsink.

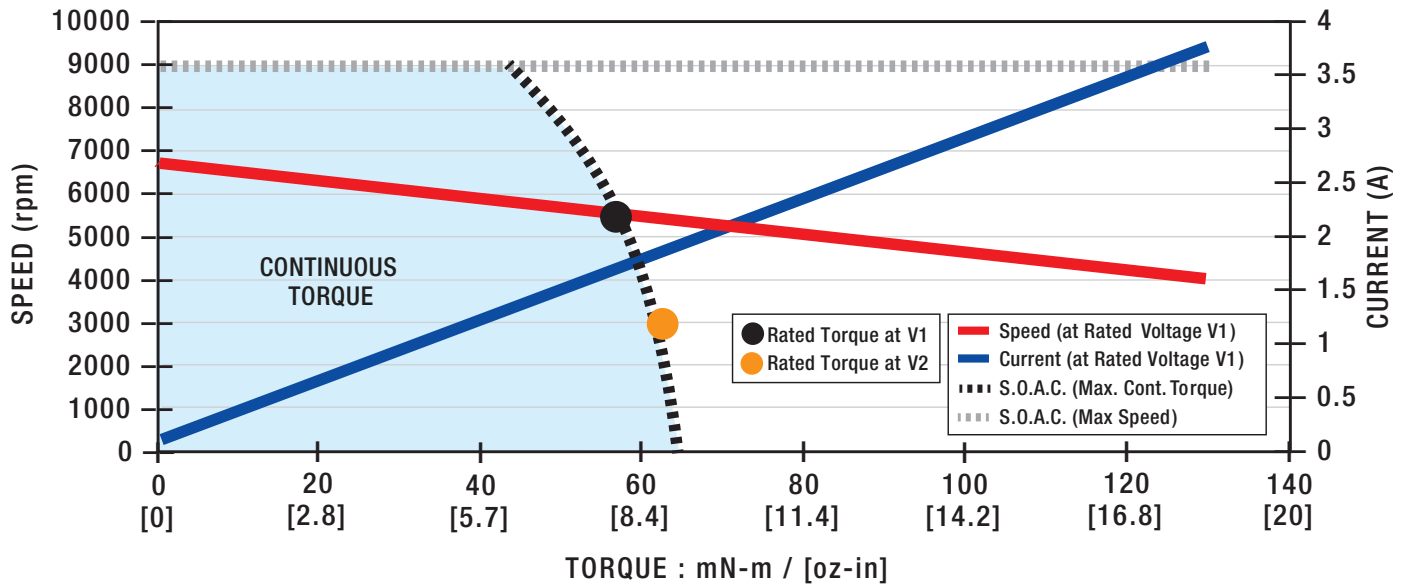

Motor Data		Units								
Rated Voltage V1	V_r	V	15.2	19.1	24.0	30.3	38.2	48.0	60.6	76.4
Rated Torque ¹ •	T_r	Nm	0.11	0.11	0.11	0.11	0.11	0.11	0.11	0.11
		oz-in	15	16	16	16	16	16	16	15
Rated Speed ¹	ω_r	rpm	5850	5810	5780	5850	5620	5620	5610	5700
Rated Current ¹	I_r	A	5.2	4.3	3.4	2.7	2.1	1.6	1.3	1.0
Rated Power ¹	P_r	W	66	67	68	69	65	65	65	65
No Load Speed	ω_{nl}	rpm	6490	6440	6410	6470	6270	6270	6260	6350
No Load Current	I_{nl}	A	0.28	0.22	0.17	0.14	0.11	0.082	0.065	0.053
Rated Voltage V2	V_r	V	9.55	12.0	15.2	19.1	24.0	30.3	38.2	48.0
Rated Torque ¹ •	T_r	Nm	0.12	0.12	0.12	0.12	0.12	0.12	0.12	0.12
		oz-in	17	17	18	18	17	17	17	17
Rated Speed ¹	ω_r	rpm	3260	3250	3270	3290	3130	3150	3140	3180
Rated Current ¹	I_r	A	5.7	4.7	3.8	3.0	2.3	1.8	1.4	1.1
Rated Power ¹	P_r	W	41	42	43	43	40	40	40	40
No Load Speed	ω_{nl}	rpm	4070	4040	4050	4080	3940	3960	3940	3990
No Load Current	I_{nl}	A	0.22	0.18	0.14	0.11	0.083	0.066	0.052	0.043
Motor Constant	K_M	Nm/ \sqrt{W}	0.042	0.043	0.044	0.044	0.043	0.043	0.043	0.042
		oz-in/ \sqrt{W}	5.9	6.1	6.2	6.2	6.0	6.1	6.0	6.0
Torque Constant	K_T	Nm/A	0.0222	0.0281	0.0355	0.0444	0.0577	0.0725	0.0918	0.114
		oz-in/A	3.14	3.98	5.03	6.29	8.17	10.3	13.0	16.1
Voltage Constant	K_E	V/(rad/s)	0.0222	0.0281	0.0355	0.0444	0.0577	0.0725	0.0918	0.114
		V/krpm	2.33	2.95	3.72	4.65	6.05	7.60	9.61	11.9
Terminal Resistance	R_{mt}	Ω	0.280	0.427	0.655	1.03	1.83	2.89	4.63	7.29
Inductance	L	mH	0.42	0.67	1.1	1.7	2.8	4.5	7.2	11
Peak Current	I_{pk}	A	18	15	12	9.6	7.2	5.7	4.5	3.6
Electrical Time Constant	τ_e	ms	1.5	1.6	1.6	1.6	1.5	1.5	1.5	1.5
Mechanical Time Constant	τ_m	ms	10	9.5	9.2	9.2	9.7	9.7	9.7	9.9

¹Recorded at maximum winding temperature at 25°C ambient and without heatsink.

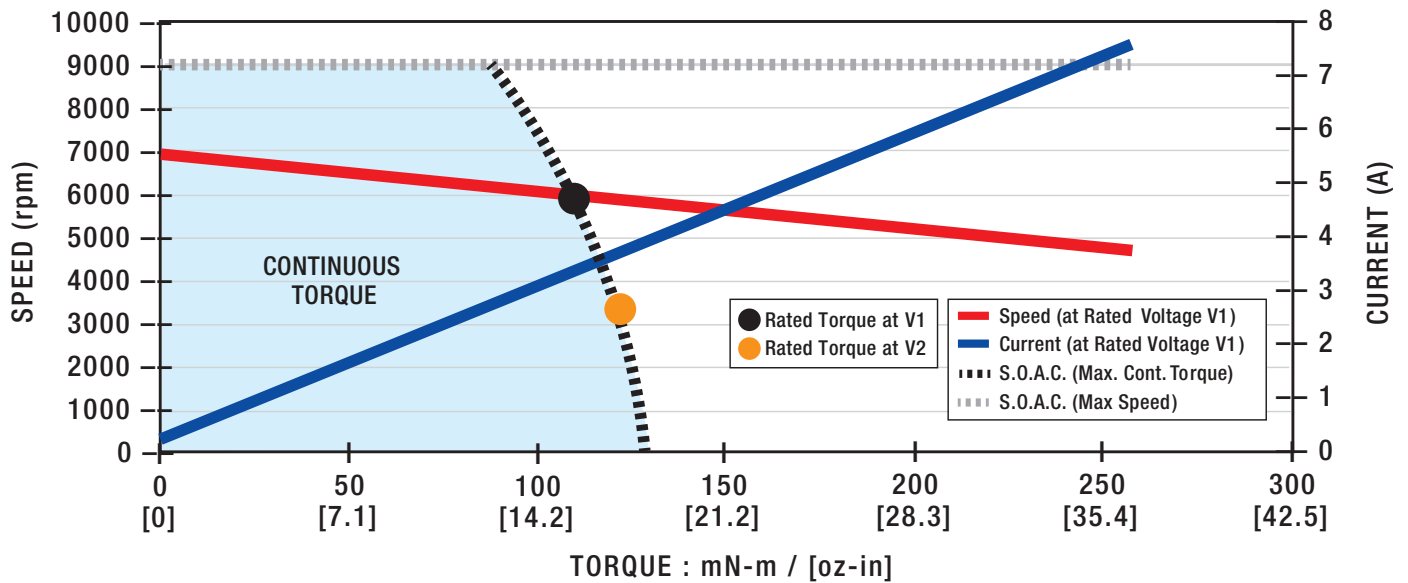

Motor Data		Units								
Rated Voltage V1	V_r	V	19.1	24.0	30.3	38.2	48.0	60.6	76.4	96.0
Rated Torque ¹ •	T_r	Nm	0.14	0.14	0.15	0.15	0.15	0.15	0.15	0.15
		oz-in	20	20	21	21	21	21	21	21
Rated Speed ¹	ω_r	rpm	6170	6220	6210	6190	6000	6220	6200	6240
Rated Current ¹	I_r	A	5.8	4.6	3.8	3.0	2.4	1.9	1.5	1.2
Rated Power ¹	P_r	W	91	93	95	95	95	98	97	98
No Load Speed	ω_{nl}	rpm	6710	6750	6730	6720	6540	6730	6720	6750
No Load Current	I_{nl}	A	0.34	0.27	0.22	0.17	0.13	0.11	0.084	0.067
Rated Voltage V2	V_r	V	12.0	15.2	19.1	24.0	30.3	38.2	48.0	60.6
Rated Torque ¹ •	T_r	Nm	0.16	0.16	0.17	0.17	0.17	0.17	0.17	0.17
		oz-in	23	23	24	24	24	24	24	24
Rated Speed ¹	ω_r	rpm	3470	3540	3520	3490	3410	3540	3510	3560
Rated Current ¹	I_r	A	6.4	5.2	4.2	3.3	2.6	2.1	1.7	1.4
Rated Power ¹	P_r	W	58	60	62	61	61	63	62	64
No Load Speed	ω_{nl}	rpm	4210	4270	4240	4220	4120	4240	4220	4260
No Load Current	I_{nl}	A	0.27	0.22	0.17	0.14	0.11	0.085	0.067	0.054
Motor Constant	K_M	Nm/ \sqrt{W}	0.050	0.051	0.052	0.052	0.053	0.053	0.053	0.053
		oz-in/ \sqrt{W}	7.1	7.2	7.4	7.3	7.5	7.5	7.5	7.6
Torque Constant	K_T	Nm/A	0.0270	0.0337	0.0427	0.0539	0.0696	0.0854	0.108	0.135
		oz-in/A	3.82	4.77	6.04	7.64	9.86	12.1	15.3	19.1
Voltage Constant	K_E	V/(rad/s)	0.0270	0.0337	0.0427	0.0539	0.0696	0.0854	0.108	0.135
		V/krpm	2.82	3.53	4.47	5.65	7.29	8.94	11.3	14.1
Terminal Resistance	R_{mt}	Ω	0.289	0.441	0.670	1.09	1.74	2.58	4.16	6.38
Inductance	L	mH	0.41	0.65	1.0	1.7	2.8	4.1	6.6	10
Peak Current	I_{pk}	A	21	17	14	11	8.4	6.9	5.4	4.5
Electrical Time Constant	τ_e	ms	1.4	1.5	1.5	1.5	1.6	1.6	1.6	1.6
Mechanical Time Constant	τ_m	ms	8.3	8.1	7.6	7.8	7.5	7.3	7.4	7.3

¹Recorded at maximum winding temperature at 25°C ambient and without heatsink.

